

Description

- 0% open area
- Dynamic open hinge, easy to clean
- Food approved materials available
- Rod diameter 5 mm (0.2")
- "Open window" sprockets

Available accessories

- Flights and Scoops
- Side guards
- Hold-down devices

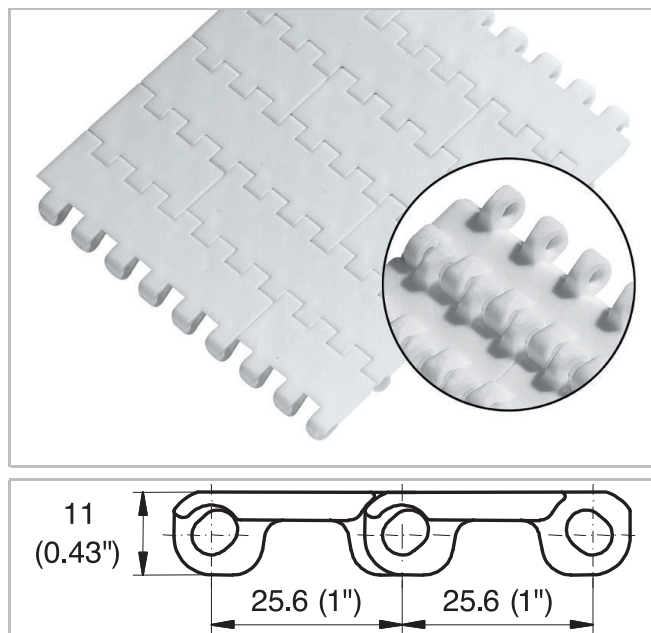

Belt data

Belt material		PP	PE	POM	
Rod material		PP	PE	PP	PA
Nominal tensile strength F'_N straight run	N/m	14000	8000	16000	21900
	lb/ft	959	548	1096	1500
Temperature range	°C	5 - 105	-70 - 65	5 - 93	-40 - 93
	°F	40 - 220	-94 - 150	40 - 200	-40 - 200
Belt weight m_B	kg/m ²	4.9	5.2	7.3	7.3
	lb/sqft	1.00	1.05	1.49	1.49

Diameter of idling rollers (minimum)		Diameter of support rollers (minimum)		Diameter for gravity take-up and center drive rollers (minimum)		Backbending radius for elevators without side guards or hold down devices (minimum)		Backbending radius for elevators with side guards or hold down devices (minimum)	
mm	inch	mm	inch	mm	inch	mm	inch	mm	inch
50	2	50	2	100	4	150	6	250.0	10

Use the largest possible backbending radius for elevators with side guards or hold-down devices.

Standard range of belt widths b_0

mm (nom.)	50	100	150	200	250	300	350	400	450	500	550	600	650	700	etc.
inch (nom.)	2	4	6	8	10	12	14	16	18	20	22	24	26	28	etc.

Real belt widths are in most cases 0.1% to 0.3% smaller.

For PE material up to 750 mm (30") -5 mm to -1 mm and -0.75% to -0.35% for wider belts.

For PP material up to 750 mm (30") -3 mm to 0 mm and -0.4% to 0% for wider belts.

For POM material up to 750 mm (30") -4 mm to 0mm and -0.3% to -0.1% for wider belts.

Standard belt widths in increments of 50 mm (2"). Non-standard widths are offered in increments of 16.66 mm (0.66"). Smallest possible width 83.4 mm (3.25"). Non-bricklaid belts 50 mm (2") and 100 mm (4") wide.

For detailed material properties refer to the HabasitLINK® Engineering Guidelines.

The nominal tensile strength is valid for 23 °C (73 °F). The admissible tensile force depends on the operating temperature near the drive sprockets. Within the temperature range allowed, the admissible tensile force may vary from 100% to 20% of the nominal tensile strength. For detailed information and correct calculation of effective tensile force refer to the Calculation Guide in the HabasitLINK® Engineering Guidelines.



Disclaimer

Product Application Disclaimer (valid for ALL Habasit products and mentioned on all PDS)

This disclaimer is made by and on behalf of Habasit and its affiliated companies, directors, employees, agents and contractors (hereinafter collectively "HABASIT") with respect to the products referred to herein (the "Products"). SAFETY WARNINGS SHOULD BE READ CAREFULLY AND ANY RECOMMENDED SAFETY PRECAUTIONS BE FOLLOWED STRICTLY! Please refer to the Safety Warnings herein, in the Habasit catalogue as well as installation and operating manuals. All indications / information as to the application, use and performance of the Products are recommendations provided with due diligence and care, but no representations or warranties of any kind are made as to their completeness, accuracy or suitability for a particular purpose. The data provided herein are based on laboratory application with small-scale test equipment, running at standard conditions, and do not necessarily match product performance in industrial use. New knowledge and experience may lead to re-assessments and modifications within a short period of time and without prior notice.

EXCEPT AS EXPLICITLY WARRANTED BY HABASIT, WHICH WARRANTIES ARE EXCLUSIVE AND IN LIEU OF ALL OTHER WARRANTIES, EXPRESS OR IMPLIED, THE PRODUCTS ARE PROVIDED "AS IS". HABASIT DISCLAIMS ALL OTHER WARRANTIES, EITHER EXPRESS OR IMPLIED, INCLUDING, BUT NOT LIMITED TO, IMPLIED WARRANTIES OF MERCHANTABILITY, FITNESS FOR A PARTICULAR PURPOSE, NON-INFRINGEMENT, OR ARISING FROM A COURSE OF DEALING, USAGE, OR TRADE PRACTICE, ALL OF WHICH ARE HEREBY EXCLUDED TO THE EXTENT ALLOWED BY APPLICABLE LAW. BECAUSE CONDITIONS OF USE IN INDUSTRIAL APPLICATION ARE OUTSIDE OF HABASIT'S CONTROL, HABASIT DOES NOT ASSUME ANY LIABILITY CONCERNING THE SUITABILITY AND PROCESS ABILITY OF THE PRODUCTS, INCLUDING INDICATIONS ON PROCESS RESULTS AND OUTPUT.